

Scroll down for Terminology

Exide Part Number

EC700

Brand Range Capacity (Ah) Box Type
↓ ↙
Exide Classic

Performance Grid

Voltage

12V

70 Ah

Ah (Ampere-hour)

640
A (EN)

Cold Cranking Amps (CCA)

Battery Dimensions

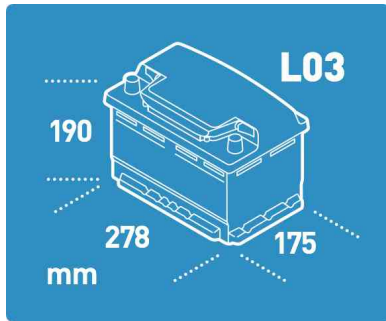

Hold-downs

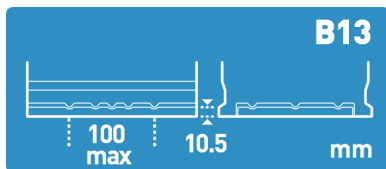

Assembly/Polarity

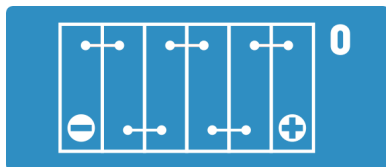

Terminal: Standard Post



European Standards:

DIN:57012

Battery Terminology:

Ampere, or Amp

The unit of measurement of current flow. One volt placed across a one ohm resistance will cause a current of one Amp to flow.

Ampere-hour or Ah

One amp for one hour is called an "amp-hour" or Ah. Ah is an indicator of the total energy the battery can store and deliver at its rated voltage. Current multiplied by time in hours equals ampere-hours. A current of one amp for one hour would be one amp-hour. The Ah performance rating of automotive batteries is measured over 20 hours of discharge, so a current of 3 amps for 20 hours would be 60 Ah.

Cold Cranking Amperes (CCA)

The CCA is an indicator of the power the battery can deliver for engine start. Consequently, bigger engines usually require higher CCA values to operate. CCA is measured in Amperes under normalised conditions (discharge at -18°C, keeping battery voltage over a minimum value) according to the standard EN50342-1.

Voltage

All modern conventional cars use a 12V battery consisting of six cells of 2V per cell. For other applications lead-acid batteries are also available in 6V.